



Tuscan Tapered Column

IPTUS0608S-TCTB FRP-PolyComp™

Tuscan Capital ArchPolymert™

12-3/4"
32.3cm

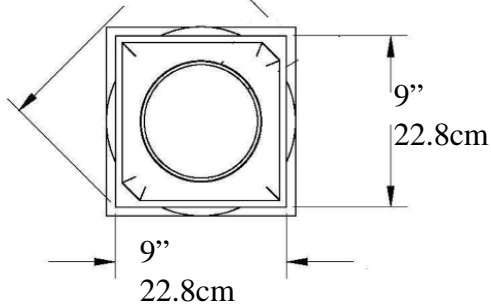

Cap 2-5/8" (6.6cm)=>

Top of Shaft
Outside Diameter
6-1/4" (15.8cm)
Minimum
Inside Diameter
5" (12.7cm)

Tuscan Base ArchPolymert™

14-1/2"
36.8cm

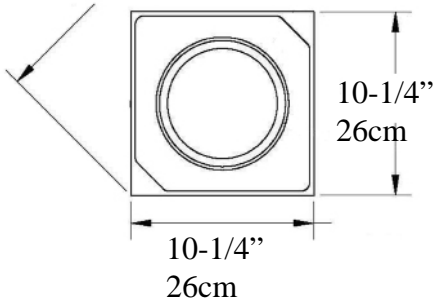

Bottom of Column
Outside Diameter
7-5/8"
19.3cm

Weight Shaft
41 lb (18.5 Kg)

Centered Load to
10,000lbs (4.53m tons)

Optional Cuts

A B C D



- A= Half column
- B = 3/4 Outside Corner
- C = Wall Cover Engaged
- D = 1/4 Column Inside Corner
- E = Engaged any percentage

Torus & Plinth
4" (10cm)

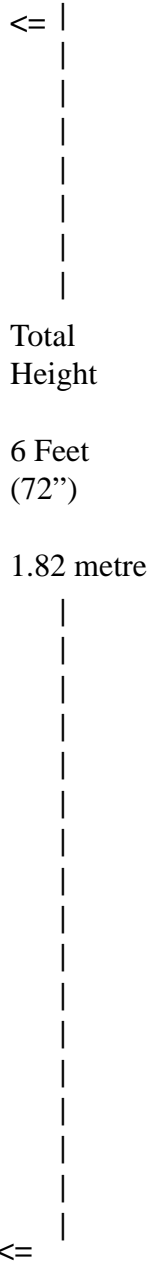

Imperial Productions®

- * assembly required, drawing not to scale Loads must be Centered on the Shaft
- * Sold as a building Component - Intergration Hardware by others
- * For Load Application check with your structural engineer for suitability in your local area
- * All specifications subject to change without notice, Final products & Measurements may vary from this brochure E/OE



Imperial Productions®

1-800-399-7585 +1-416-264-6096

Imperial Productions & Distribution Inc

email sales@imperialproductions.com copyright 2016 MRDCI All Rights Reserved

SEP-25



Custom Request (Download & Fill-in)

sales@imperialproductions.com IPTUS0608S-TCTB

Name _____

Contact: _____

Phone # _____

Email: _____

Address _____
_____ ZIP/PC _____

FRP-PolyComp™ A Composite Gypum, Fiberglass, Marble Chips, Prime & Paint by others

(Interior/Exterior)

of Whole Units _____ # of Split Units _____

Type of Split enter Letter _____

Optional Cuts

A B C D



A= Half column

B = 3/4 Outside Corner

C = Wall Cover Engaged

D = 1/4 Column Inside Corner

E = Engaged any percentage

* Possible Limitations due to Quantity Requested and/or Application



Imperial Productions®

1-800-399-7585 +1-416-264-6096

Imperial Productions & Distribution Inc.

email sales@imperialproductions.com copyright 2016 MRDCI All Rights Reserved